



Video Sentinel® Camera VSC510

Lens

3.6mm – 82.8mm
23x Optical Zoom F1.6

Field of View

Horizontal: 54° (W)
2.5° (T)

Focus

Auto (VAF),
Manual (Far/Near)

Focus Distance

Infinity – 1m (T)
.01 (W) (Manual Mode)

Construction

Cast and Machined
356 T51 Al Alloy

Finish

Polyurethane Paint
Cardinal White

Environment

All Weather Gasketed
Housing, Sealed Connector

Temperatures (C)

Operation -40 - +80 Deg
Storage -65 - +150 Deg

Weight

4.1 lbs.

Signal

NTSC Video UTP

Sensor

1/4" WDR/HS Progressive
Scan CCD

Resolution

470 Horizontal TVL

S/N Ratio

50dB

Sensitivity

IP On – 3 lx Color,
IR Off - .02 lx BW (Minimum)

Sync System

Internal

Product Benefits

- **High Resolution Color Images** when used with our VSM or CVM color monitors for excellent picture quality.
- **Motorized 23X Optical Zoom Lens** provides extremely detailed viewing, impossible with standard cameras.
- **Removable IR Cut-Filter** automatically switches from color to black-and-white for optimal viewing in very low-light conditions.
- **Compatible** with Intec VSX351 Series Controllers.
- **Optional RF Transmission** enables the ultimate in viewing flexibility.

Dimensions

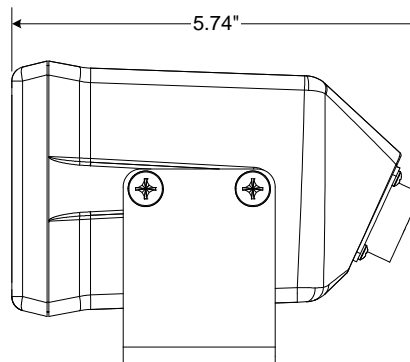
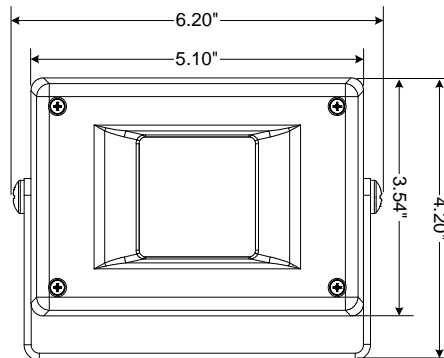

For service and literature:

www.intecvideo.com
West: 800-468-3254
East: 800-522-5989

Intec Video Systems, Inc.
23301 Vista Grande
Laguna Hills, CA 92653

VSC510 SPEC 02/08

Intec® and Video Sentinel® are registered trademarks of Intec Video Systems, Inc.

© 2008 Intec Video Systems, Inc.

Specifications Subject to Change
Without Prior Notice.